

ISTRUZIONI DI MONTAGGIO

ASSEMBLY INSTRUCTIONS

- 1) Fissare i regolatori millimetrici a plafone
- 1) Fix the millimetric adjustment system for ceiling

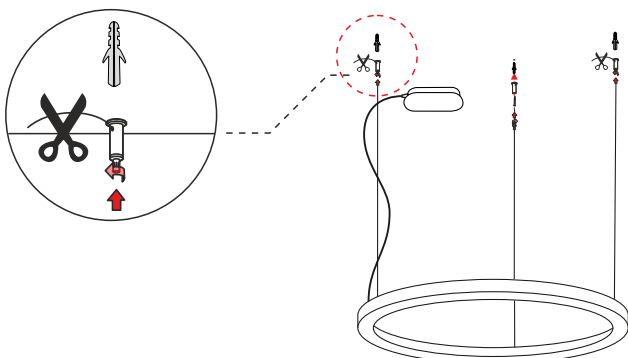

- 2) Aprire la cover
- 2) Open the cover
- 3) Fissare il rosone
- 3) Fix the ceiling rose

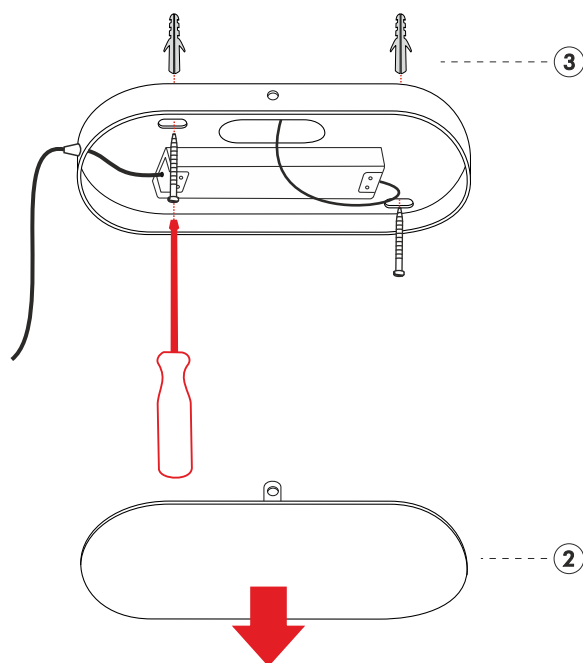

- 4) Effettuare il collegamento elettrico
- 4) Make the electrical connection
- 5) Richiudere la cover
- 5) Close the cover

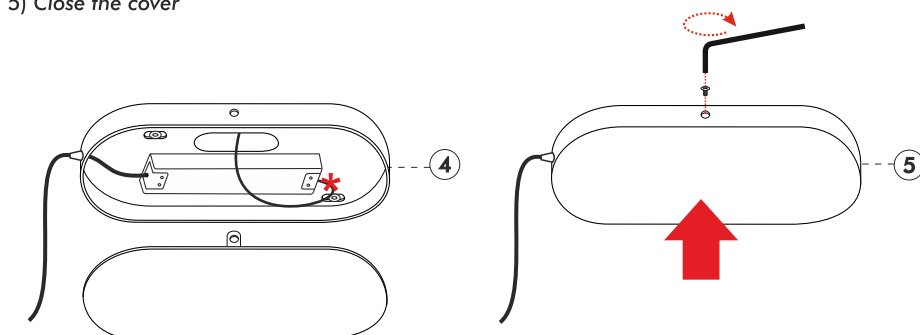

PRODOTTO / PRODUCT

BELLAI HOME

MONTAGGIO / MOUNTING

Sospensione / Suspension

CODICI / CODES

1027AOF - 1027ADM
1027BOF - 1027BDM
1027COF - 1027CDM
1027DOF - 1027DDM
1027EOF - 1027EDM - 1027ETF

n°INSTALLATORI / INSTALLERS n°



STRUMENTI / INSTRUMENTS



TEMPO / TIME



CERTIFICAZIONI / CERTIFICATIONS



ATTENZIONE / CAUTION



Togliere la rete di alimentazione prima dell'installazione, sostituzione della lampada e comunque prima di ogni operazione di manutenzione.

Always turn off power supply before install, replacing of the light bulb and prior to any maintenance interventions.



La sicurezza dell'apparecchio è garantita solo con l'uso appropriato delle seguenti istruzioni; pertanto è necessario consultarle e conservarle.

The safety of this product is guaranteed only if correctly used, according to this instruction sheet, which must be read first

COLLEGAMENTO ELETTRICO * ELECTRICAL CONNECTION



Attenzione! Togliere la rete di alimentazione prima dell'installazione, sostituzione della lampada e comunque prima di ogni operazione di manutenzione.

Caution! Always turn off power supply before install, replacing of the light bulb and prior to any maintenance interventions.

Versione ONOFF ONOFF Version

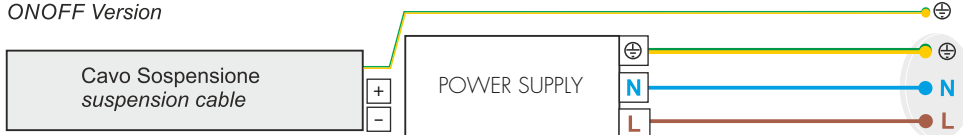

Versione dimmerabile - Collegamento con pulsante Dimmable Version - Touch-DIM wiring

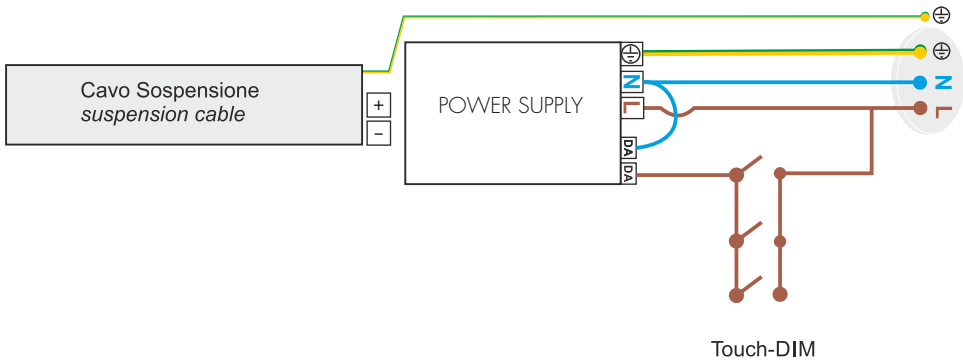

Versione dimmerabile - Collegamento con sistema di gestione Dimmable Version - Management System wiring

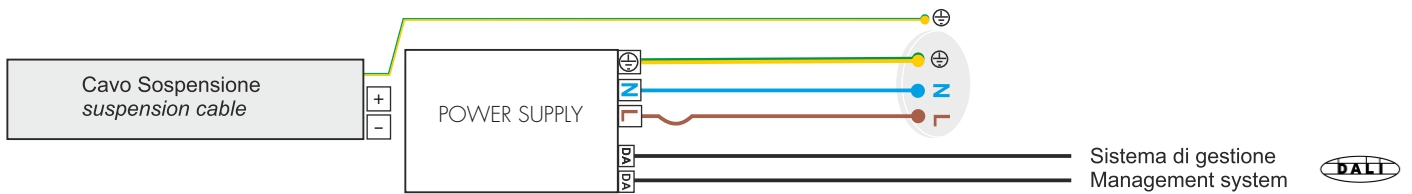

Versione TAGLIO DI FASE

